

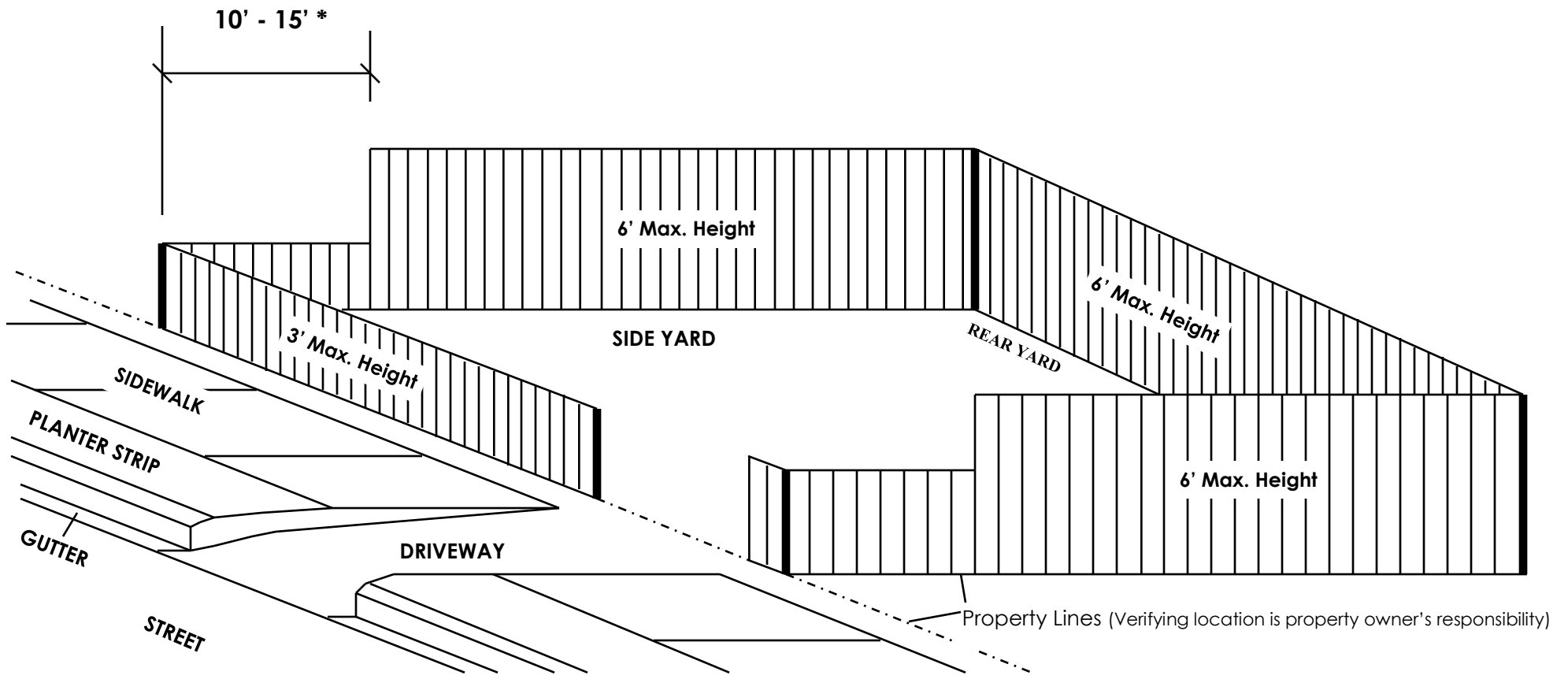

# ALBANY CALIFORNIA

## REGULATIONS FOR FENCES, WALLS, & HEDGES ON INTERIOR RESIDENTIAL LOTS



\* No fence, wall, or hedge may be taller that 3' in this area. Depth of height-restricted area depends on location of house on lot. (See reverse for illustrations of this area.)



# ALBANY CALIFORNIA

## ILLUSTRATION OF AREA FOR 3' FENCE HEIGHT MAXIMUM

**Case #1:** House is 15' or more from front property line:

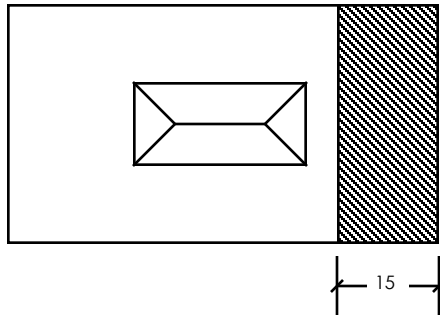

15' deep area is 3' height-restricted (no fences, wall, or hedges may be taller than 3' in this area)

**Case #2:** House is less than 15' but at least 10' from front property line:

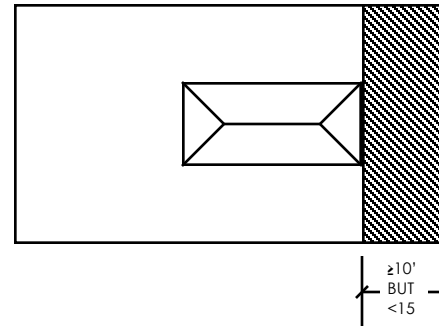

All of front yard is 3' height-restricted (no fences, walls, or hedges may be taller than 3' in this area)

**Case #3:** House is less than 10' from front property line:

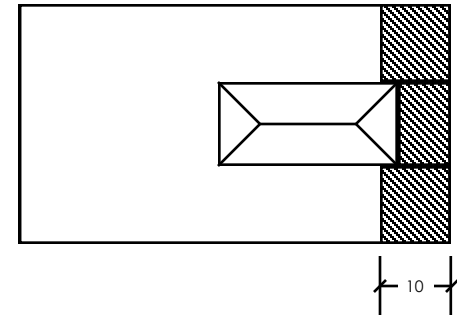

10' deep area is 3' height-restricted (no fences, wall, or hedges may be taller than 3' in this area)



# ALBANY CALIFORNIA

## Supplementary Height Regulations for Fences, Walls, & Hedges on Corner Lots

1. Height regulations for fences, walls, and hedges in the front yard of a corner lot are the same as those for the front yard of interior lots.
2. Height regulations for fences, walls, and hedges in the street-side side yard of a corner lot are illustrated in the diagram below:

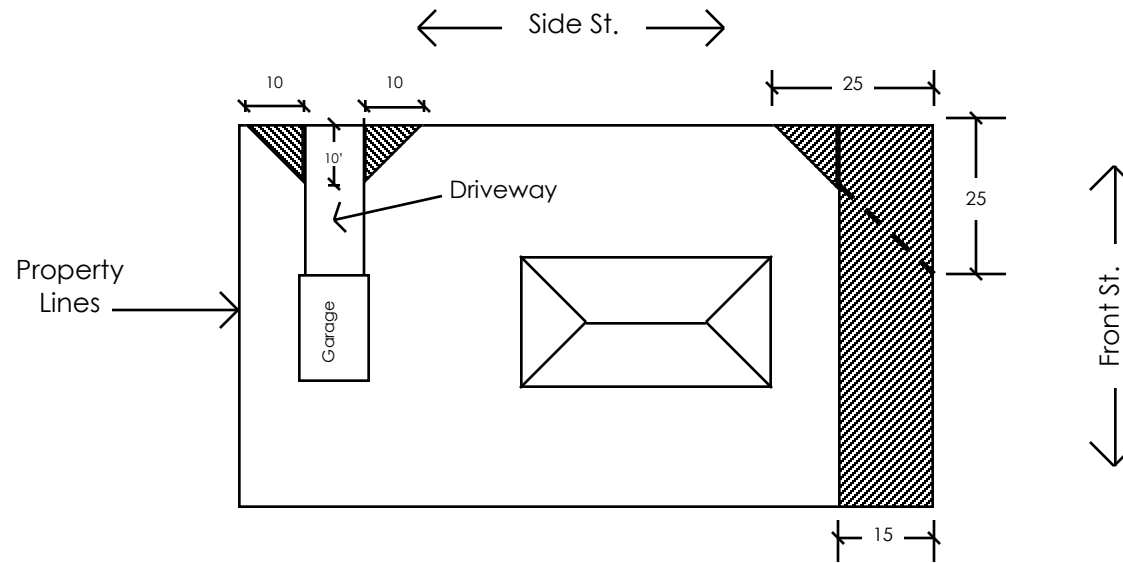

Shaded areas are 3' height-restricted (no fences, walls, or hedges taller than 3' in this ar-

- A 10' "vision triangle" must be maintained around a driveway on the street-side side yard of a corner lot.
- A 25' "vision triangle" must be maintained around the street-side corner of a corner lot.